

# M-410iC/185



Max. load capacity  
at wrist: 185 kg



Max. reach:  
3143 mm

# FANUC

Robot			Max. load capacity at wrist (kg)	Reach (mm)	Controlled axes	Repeatability (mm)	Mechanical weight (kg)	Motion range (°)						Maximum speed (°/s)						J4 Moment/ Inertia	J5 Moment/ Inertia	J6 Moment/ Inertia	Average Power consumption (kW)	Protection	
Series	Version	Type						J1	J2	J3	J4	J5	J6	J1	J2	J3	J4	J5	J6					Body standard/optional	Wrist & J3 arm standard/optional
M-410	iC	185	185	3143	4	±0.05**	1600 (1330)	360	144	136	720	-	-	140	140	140	305	-	-	88	-	-	3	IP54	IP54

[no pedestal] ● standard ○ on request - not available \*\* Based on ISO9283

M-410iC/185

Hollow wrist



Rear side  
Interference area

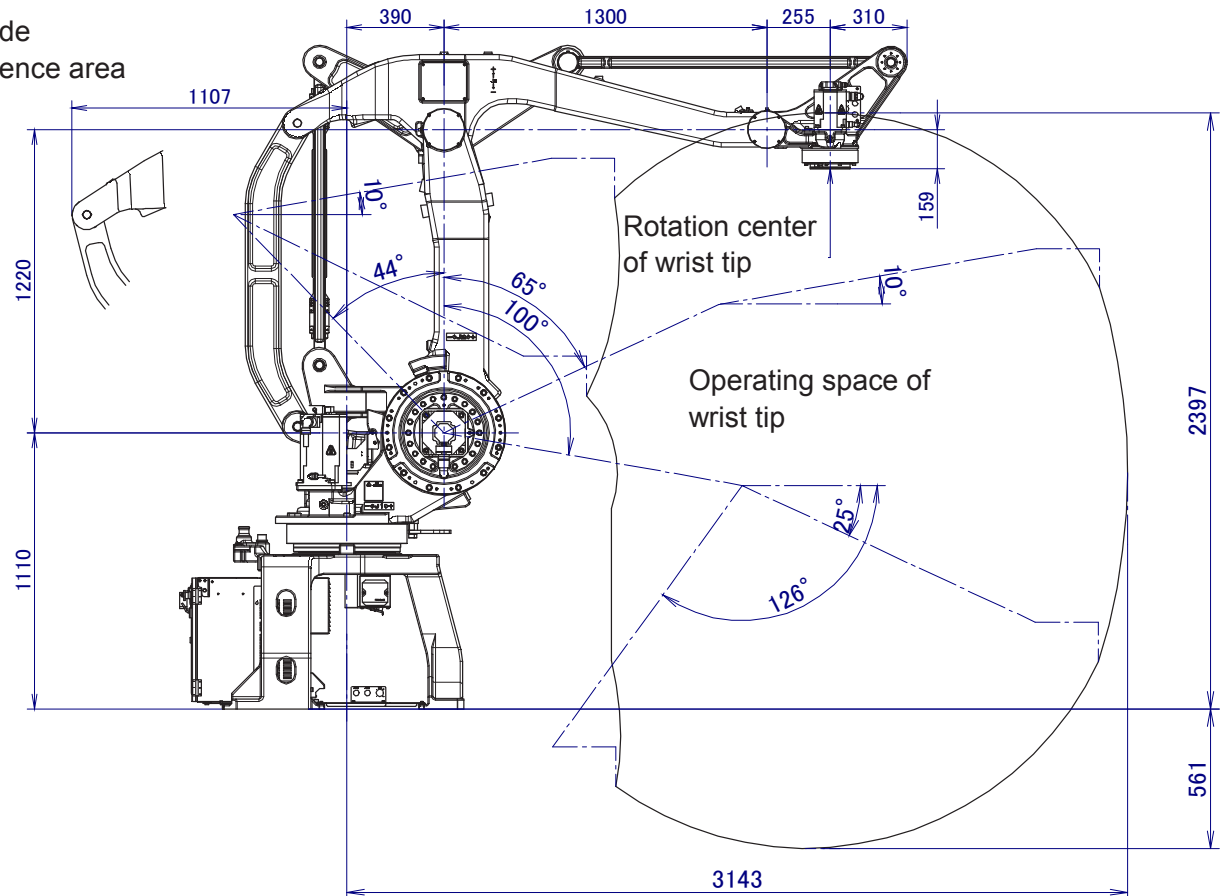

M-410iC/185