

# SR-3iA/U



Max. load capacity  
at wrist: 3 kg



Max. reach:  
350 mm

# FANUC

Robot			Max. load capacity at wrist (kg)	Reach (mm)	Controlled axes	Repeatability (mm)	Mechanical weight (kg)	Motion range (°)						Maximum speed (°/s)						Moments (N-m)/Inertia (kg-m <sup>2</sup> )			Push Force (N)	Protection	
Series	Version	Type						J1	J2	J3	J4	J5	J6	J1	J2	J3	J4	J5	J6	J4 Moment/Inertia				Body standard/optional	Wrist & J3 arm standard/optional
SR	iA/U	3	3	350	4	±0.01 (J1, J2) ±0.01 (J3) ±0.004° (J4)	27	±225	±225	140 mm	±720	-	-	610	840	1500 mm/s*	3000°/s	-	-	-/0.06	,	,	150	IP20	IP20

- not available \* z axis

SR-3iA/U 4-axis

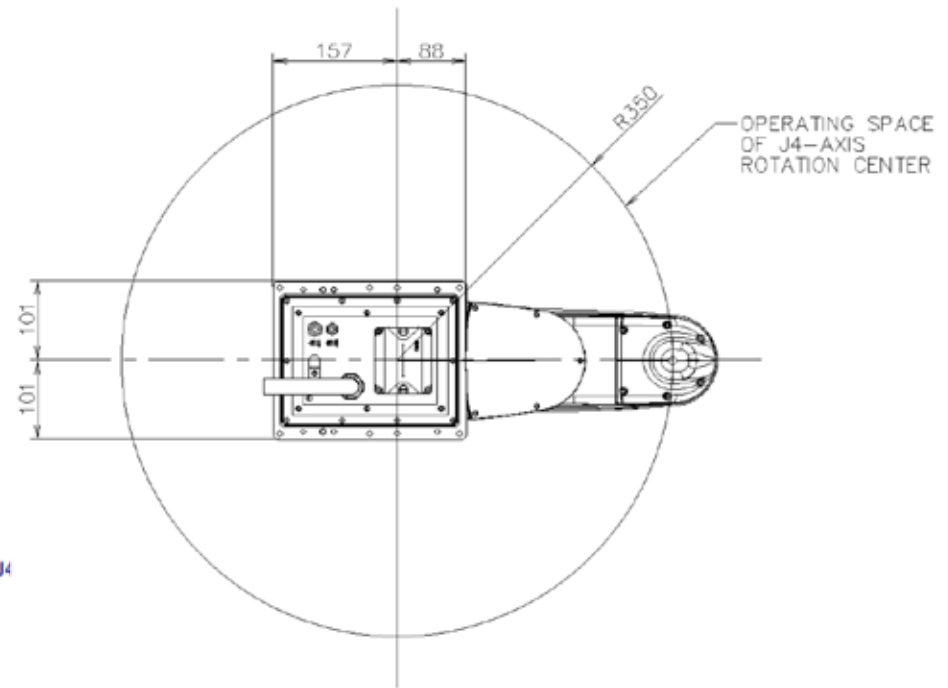
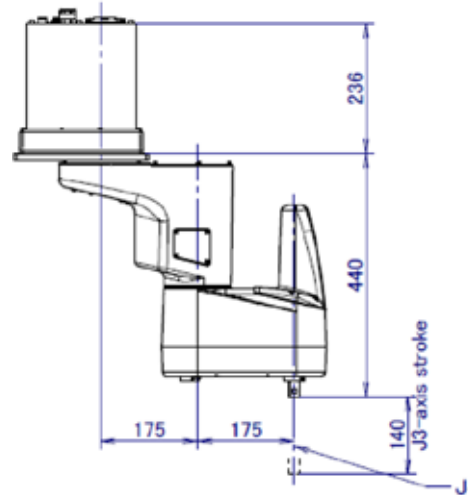

SR-3iA/U