

Paint Mate 200iA



Max. load capacity at wrist: 5 kg



Max. reach: 892 mm*

FANUC

Design

The FANUC Paint Mate robot is an intelligent, electric servo-driven paint robot with a small footprint and versatile envelope.

Working range Paint Mate 200iA

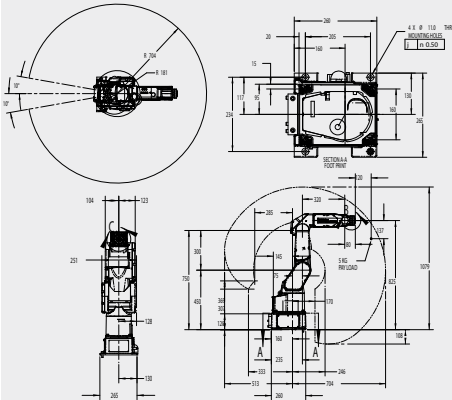

Working range Paint Mate 200iA/5L

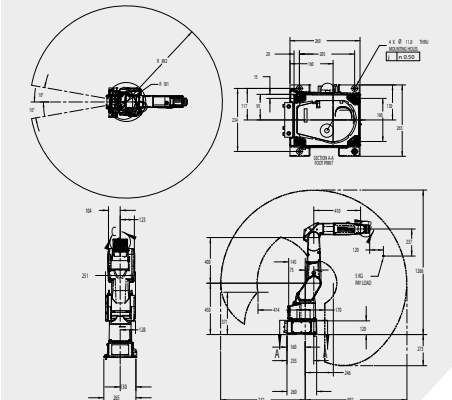

Features

- Can be used for small parts painting or a material saving alternative to multiple fixed guns
- Best-in-class performance designed for operation in a hazardous environment
- Based on the highly-acclaimed LR Mate® series
- Envelopes, speed, and dexterity are a perfect fit for coatings and hazardous duty applications
- iRVision controller integrated with every robot
- Offline teaching capability
- Parallel J2 link allows smooth motion
- High Reliability with FANUC standard purge module
- Utilizes FANUC toolbox of MH software:
 - Collision guard
 - Accuracy tools
 - Advance constant path

Options

- Floor, angle, and ceiling mount configurations
- One or four pneumatic three-way solenoid valves located in the purge cavity for gun triggering capability
- Slim Arm:
 - Suitable at narrow space operation
 - Lightest weight (35kg) in its class
- Purged and Pressurized Arm:
 - FM and ATEX Class 1 Div.1 Approved
 - 1.8 min Purge Time



* For the Paint Mate 200-iA/5L

Paint Mate 200iA



Max. load capacity
at wrist: 5 kg



Max. reach:
892 mm

FANUC

Robot			Max. load capacity at wrist (kg)	Reach (mm)	Controlled axes	Repeatability (mm)	Mechanical weight (kg)	Motion range [°]						Maximum speed [°/s]						Allowable load moment at wrist (Nm) Allowable load inertia at wrist (kg m ²)			Input power source (VAC) (50-60 HZ)
Series	Version	Type						J1	J2	J3	J4	J5	J6	J1	J2	J3	J4	J5	J6	J4	J5	J6	
Paint Mate	iA	-	5	704	6	± 0.02	35	340	200	388	380	240	720	350	350	400	450	450	720	11.9 .3	11.9 .3	6.7 .1	200-230 +10/-15%
Paint Mate	iA/5L	-	5	892	6	± 0.03	37	340	230	373	380	240	720	270	270	270	450	450	720	11.9 .3	11.9 .3	6.7 .1	200-230 +10/-15%

Paint Mate 200iA

Paint robot



Paint Mate 200iA

Paint Mate 200iA

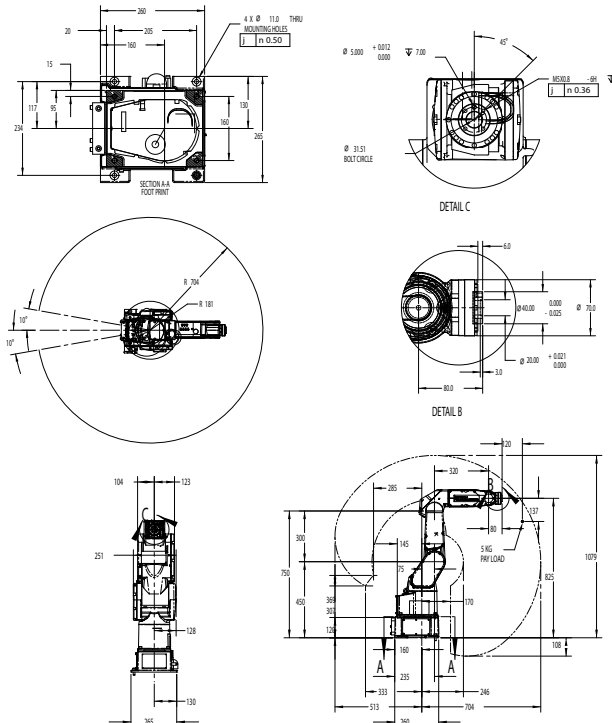

Paint Mate 200iA/5L

