

# FANUC

## Hollow arm meets full productivity



**FULLY INTEGRATED  
PROCESS CABLES**  
to ensure protection of  
process cables and  
prevention of interference  
with system equipment



**LONG LIFETIME**  
High durability and  
maintainability for  
process cables



**SPACE SAVING DESIGN**  
23 % decrease of installation  
area compared to former  
series



**100 KG PAYLOAD**

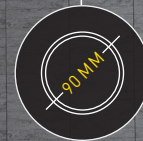

**LARGE HOLLOW WRIST  
OF 90 MM** and hollow arm



**EASY SYSTEM STUDY**  
with offline teaching

**NEW**

**R-2000iD/100FH**

### **NEW FANUC R-2000iD series: Compact design and easy maintenance**

- Reduction of maintenance time and costs due to optimised long-life cables
- Number of strategic openings ensure easy access to cables
- Easy and precise offline simulation with ROBOGUIDE
- Ideally equipped for applications like spot welding or material handling applications

# R-2000iD/100FH



Max. load capacity  
at wrist: **100 kg**



Max. reach:  
**2605 mm**

Controlled axes	Repeatability (mm)	Mechanical weight (kg)	Motion range [°]						Maximum speed [°/s]						J6 Moment/Inertia (Nm/kgm <sup>2</sup> )	J5 Moment/Inertia (Nm/kgm <sup>2</sup> )	J4 Moment/Inertia (Nm/kgm <sup>2</sup> )	J6 Moment/Inertia (Nm/kgm <sup>2</sup> )
			J1	J2	J3	J4	J5	J6	J1	J2	J3	J4	J5	J6				
6	± 0.05	1150	370	140	234	420	250	420	105	130	130	200	160	300	850/90	850/90	450/50	

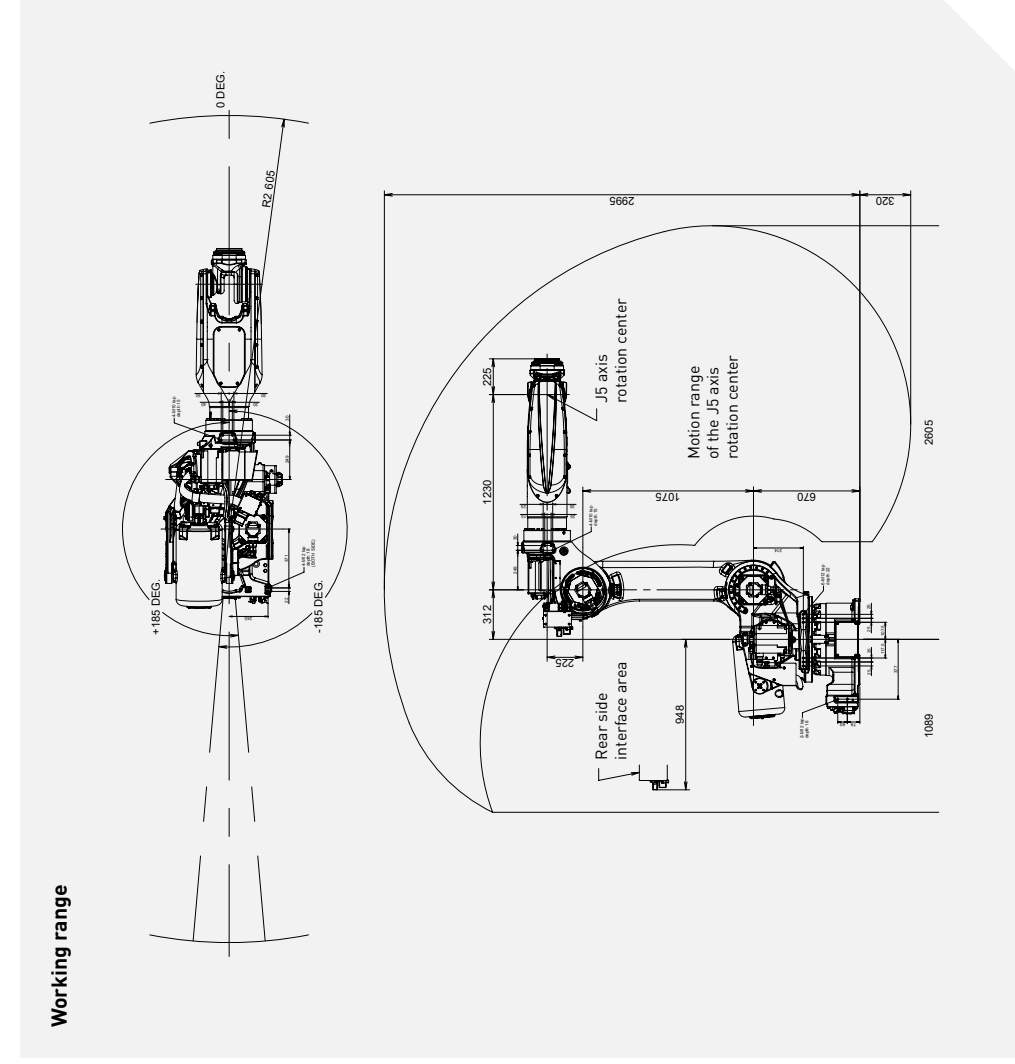

**Robot**

- Robot footprint [mm] ..... 678 x 536
- Mounting position Floor ..... ●
- Mounting position Upside down ..... -
- Mounting position Angle ..... -

**Controller**

- Open air cabinet ..... -
- Mate cabinet ..... ○
- A-cabinet ..... ●
- B-cabinet ..... ○
- iPendant Touch ..... ●

**Electrical connections**

- Voltage 50/60Hz 3phase [V] ..... 380-575
- Voltage 50/60Hz 1phase [V] ..... -
- Average power consumption [kW] ..... 2.5

**Integrated services**

- Integrated signals on upper arm In/Out ..... 8/8
- Integrated air supply ..... 2

**Environment**

- Acoustic noise level [dB] ..... 69,8
- Ambient temperature [° C] ..... 0-45

**Protection**

- Body standard/optional ..... IP54
- Wrist & J3 arm standard/optional ..... IP67

● standard ○ on request - not available ( ) with hardware and/or software option \*Based on ISO9283