

CRX-30iA



Max. load capacity
at wrist: 25/30 kg



Max. reach
(end of flange):
1889 mm

FANUC

Robot			Max. load capacity at wrist (kg)	****Reach (mm)	Controlled axes	***Repeatability (mm)	Mechanical weight (kg)	Motion range (°)						**Maximum speed (°/s)		****Allowable Wrist Load			Protection		
Series	Version	Type						J1	J2	J3	J4	J5	J6	Collaborative Mode [mm/sec]	High Speed Mode [mm/sec]	J4 Moment/ Inertia	J5 Moment/ Inertia	J6 Moment/ Inertia	Input power source (VAC)	Body standard	Wrist & J3 arm
CRX	iA	30	30 25	1756 1889*	6	± 0.05	135	360	360	540	380	360	450	1000	2000	100.0/ 4.7	74.0/ 4.00	32.0/ 2.00	100-120 200-240	IP67	IP67

● standard ○ on request - not available *Operating space is expanded when 25kg payload mode is selected **Please set motion speed according to risk assessment of system. ***Based on ISO9283 ****Nm/Kg.m² *****At the end of flange

CRX-30iA Food-Grade Variant

NSF H1 food-grade grease,
White USDA compliant epoxy coating



CRX-30iA

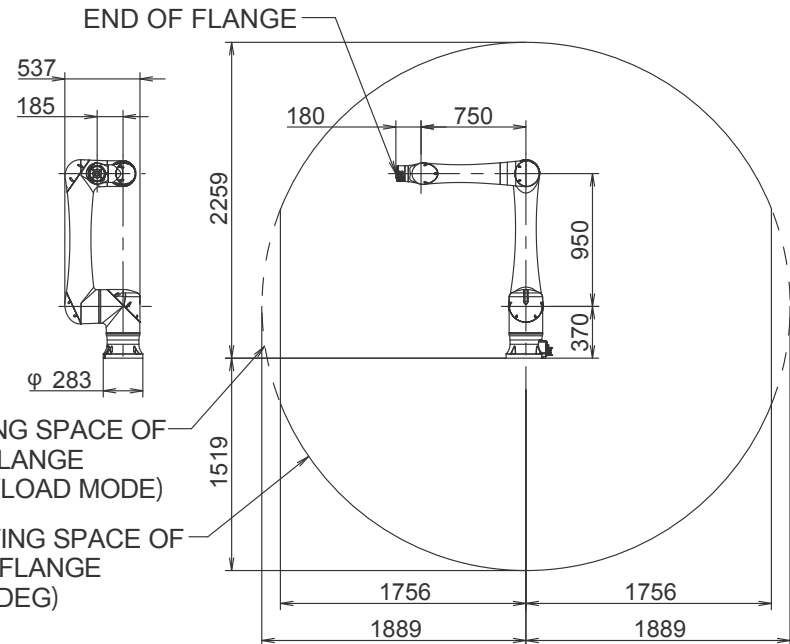
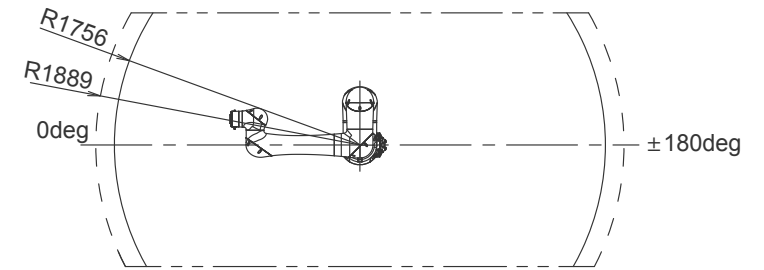

OPERATING SPACE OF
END OF FLANGE
(25kg PAYLOAD MODE)

OPERATING SPACE OF
END OF FLANGE
(J4=+90 DEG)