

P-35iA



Max. speed:
1500 mm/s



Max. reach:
4318 mm

FANUC

Design

The FANUC P-35iA is a robot for opening and closing hoods and deck lids to paint interior surfaces of automobile bodies.

Working range P-35iA

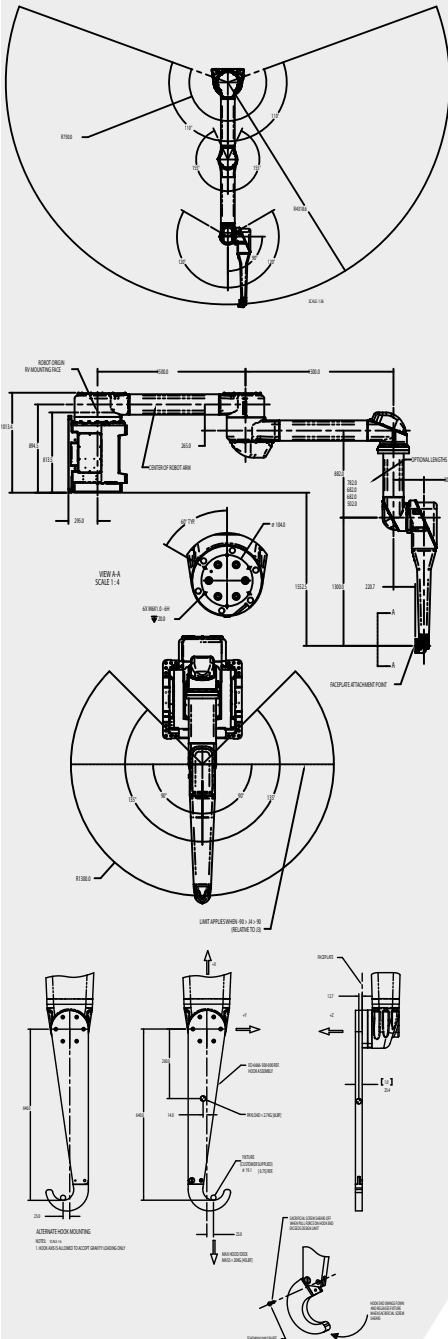

Features

- Vertical articulation saves space and enables a high-density layout
- Applicable for both stop-and-go and moving-line solutions
- Designed for high-speed moving line applications
- Reduced maintenance design improves system uptime
- Tooling is easily removed for maintenance
- Ability to operate independently from painting robot maximizes cycle time

Options & Software

- Standalone or coordinated controller
- Can be mounted in conjunction with the P-1000 or as a standalone pedestal
- Independent group motion allows the P-35iA and other FANUC paint robots to perform separate tasks simultaneously
- Built-in software features simplify path teaching and help users coordinate independent motion groups and decreasing required spray zone length

Specifications

Robot	Series	P-35
	Version	iA
Break away pull force hook		80-KGF 175-LBF
Holding capacity hook		20-KGF 45-LBF
Reach (mm)		4318
Controlled axes		5
Mounting		Pedestal
Mechanical weight (kg)		700
Axis reach (mm)	Axis 1	1600
	Axis 2	1600
	Axis 3	882
	Axis 4	1300
	Axis 5	Hook
Max. speed (°/s)	Axis 1	75
	Axis 2	100
	Axis 3	100
	Axis 4	50
	Axis 5	50

