

LR Mate 200iD/7C



Max. load capacity
at wrist: 7 kg



Max. reach:
717 mm

FANUC

Robot			Max. load capacity at wrist (kg)	Reach (mm)	Controlled axes	Repeatability (mm)	Mechanical weight (kg)	Motion range (°)						Maximum speed (°/s)						Moments (N-m)/Inertia (kg-m ²)			Protection		
Series	Version	Type						J1	J2	J3	J4	J5	J6	J1	J2	J3	J4	J5	J6	J4 Moment/Inertia	J5 Moment/Inertia	J6 Moment/Inertia	Average Power consumption (kW)	Body standard/optional	Wrist & J3 arm standard/optional
LR Mate 200	iD	7C	7	717	6	±0.01**	25	340 (360)	245	420	380	250	720	450	380	520	550	545	1000	16.6/.47	16.6/.47	9.4/.15	0.5	IP67/ IP69K	IP67/ IP69K

[option] ● standard ○ on request - not available () with hardware and/or software option ** Based on ISO9283

LR Mate 200iD/7C Clean room, food grade grease (2 integrated solenoid valves)



LR Mate 200iD

Operating space of J5-axis rotation center

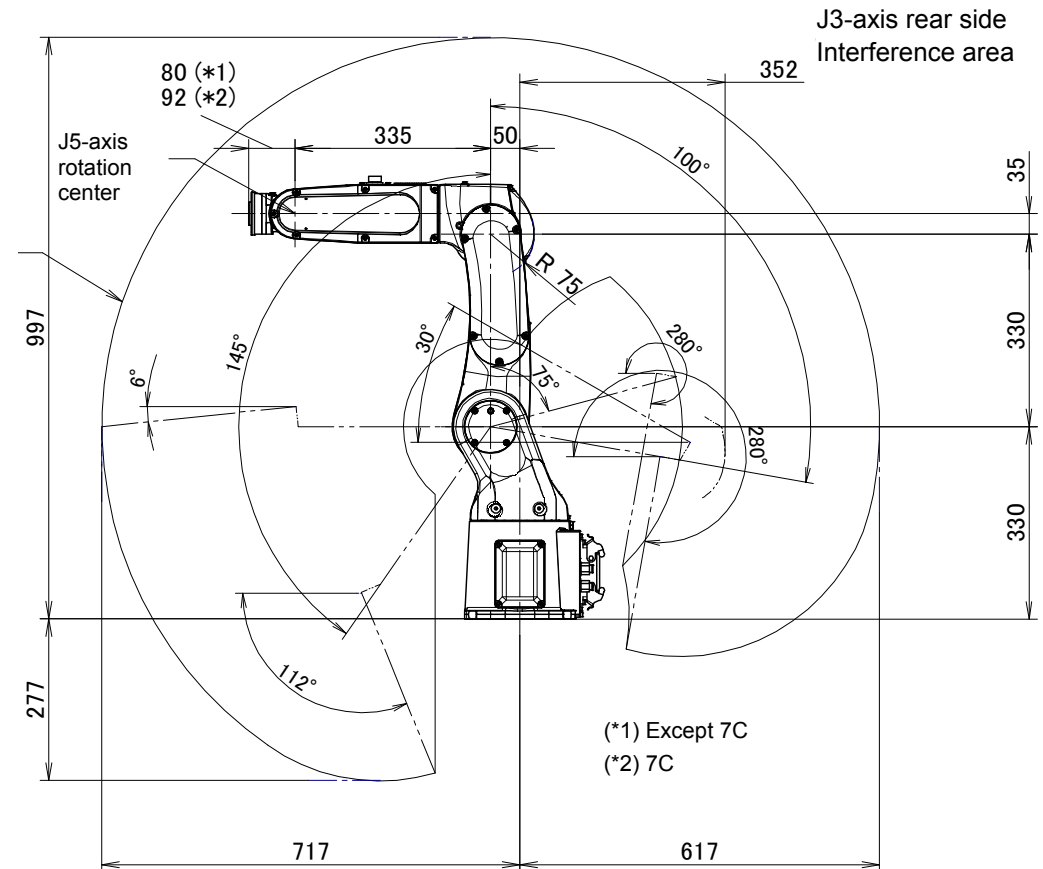

» If applied load on the robot exceeds 5kg when the robot is installed on an angle, the operating area is limited by the mount angle. If payload is less than 5kg, there is no restriction of the operating space.